

# TOOLING & ACCESSOIRES FOR WOOD TURNING INDUSTRIES :

*(Short brochure 08/2019)*

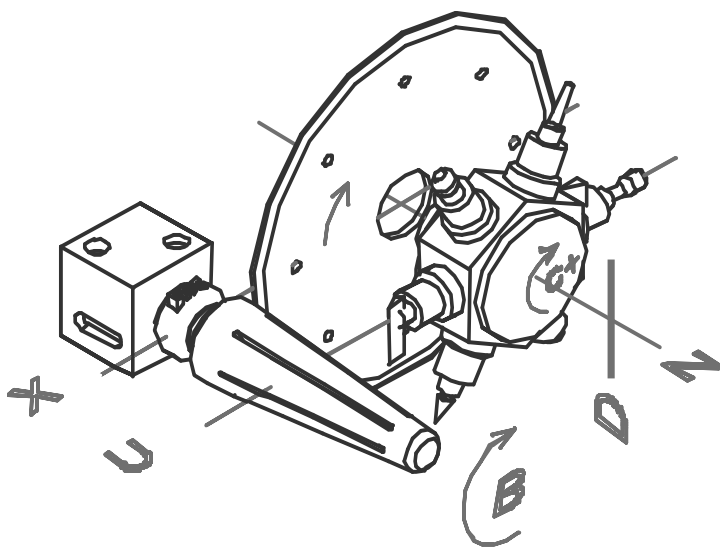
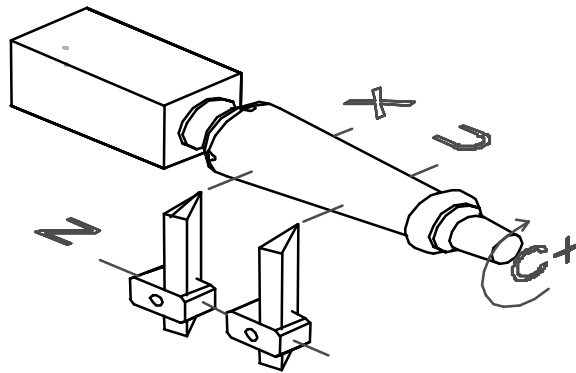
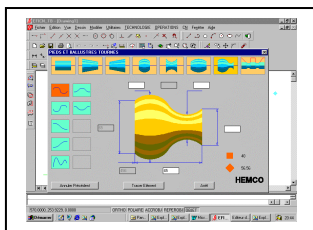
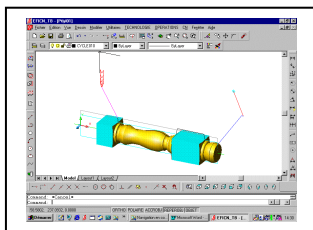
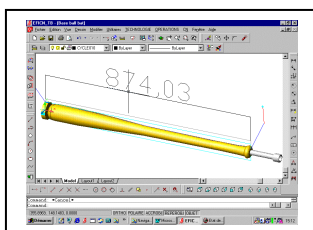
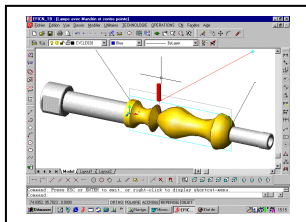

**HEMPEL**

**CNC Machines**

Hempel machines Atelier Fallecker Sarl  
F26400 Mirabel et Blacons - France

Tel. : +33 (0) 4 75 40 06 03 E-mail : [Info@hempel-machines.com](mailto:Info@hempel-machines.com) [www.hempel-machines.com](http://www.hempel-machines.com)

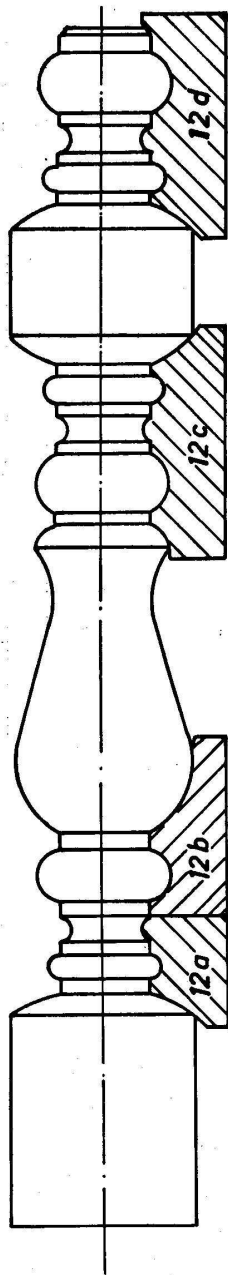

**Form-tools in HSS-C**  
 (We realize model from a squetch or a wooden model)

**GOUGES STANDARD**

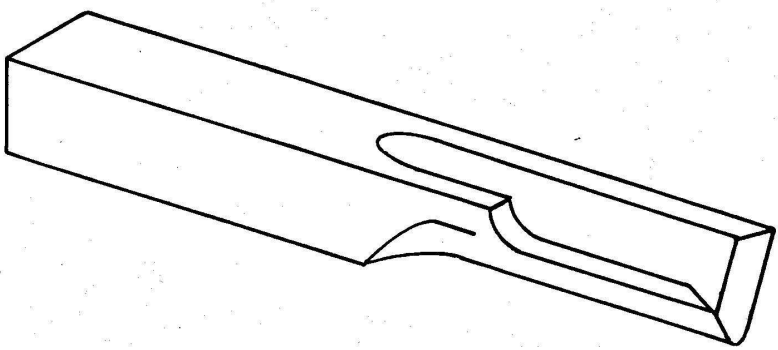

**GOUGES en " V é "**

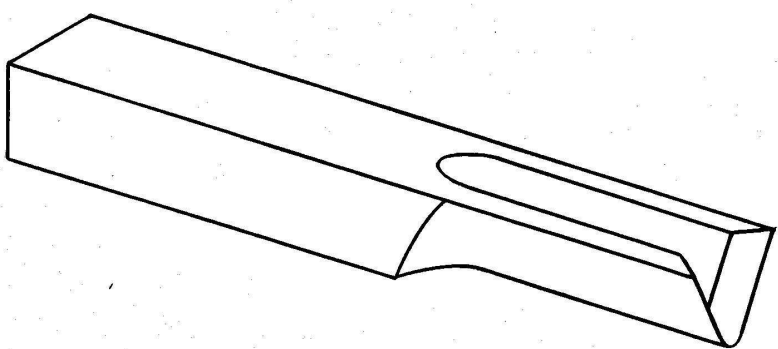

**GOUGES SPECIALES**

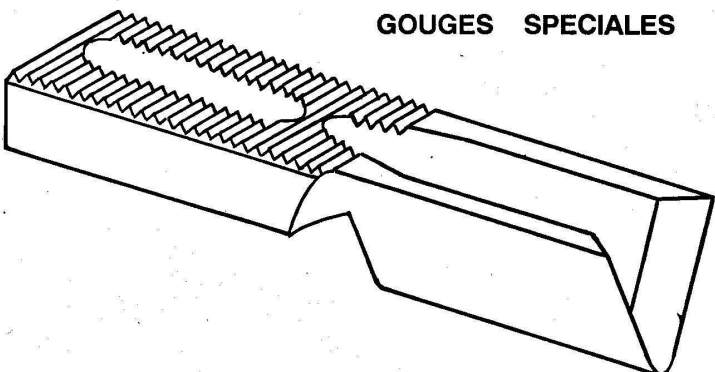

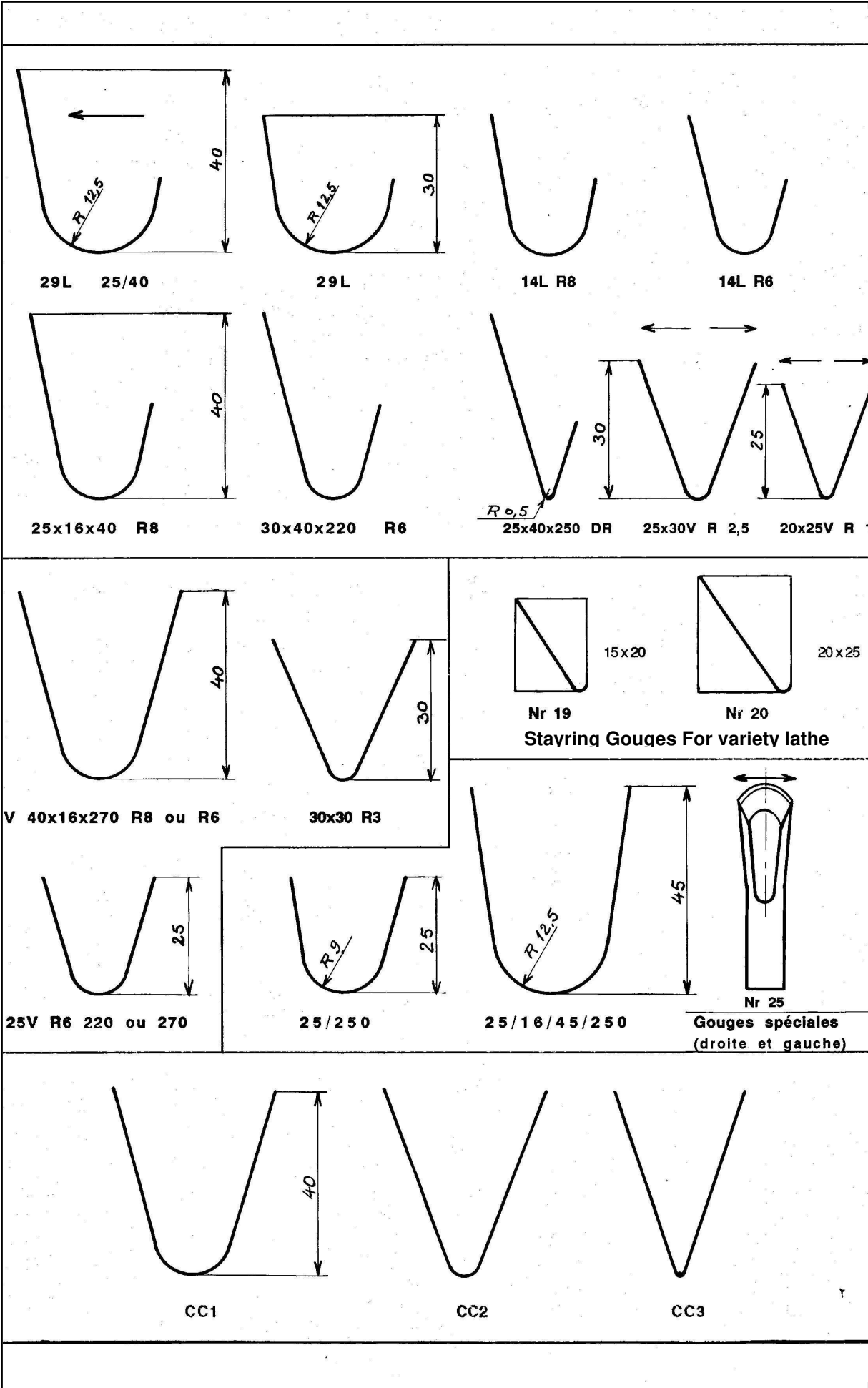

Sharp tools for copiers machines

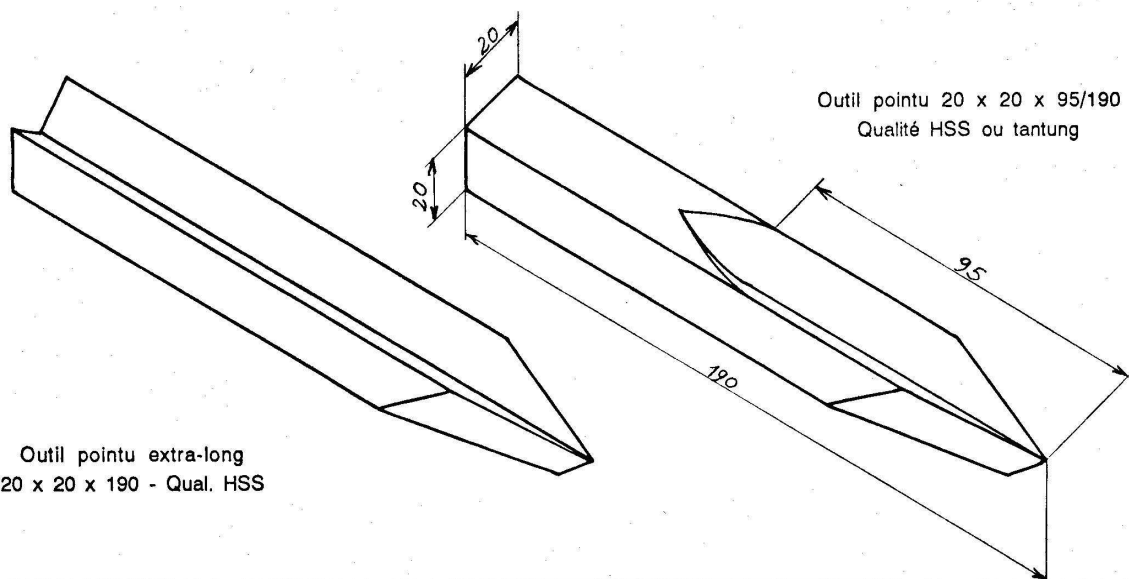

Outil pointu extra-long  
20 x 20 x 190 - Qual. HSS

Outil pointu 20 x 20 x 95/190  
Qualité HSS ou tantung

raise spéciale pour CKE

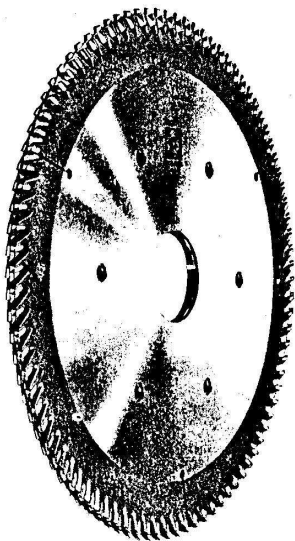

Outil pointu ERSP

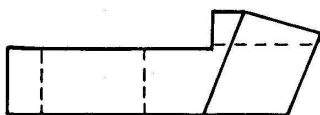

Gouge coquille ERSP

Rotation 360° possible  
Qualité HSS ou HM

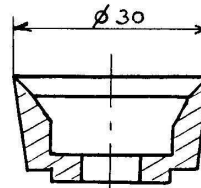

Outil pointu CKS

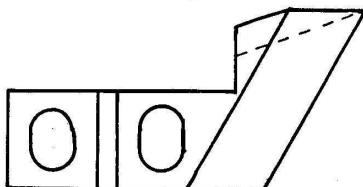

OUTIL à tronçonner



N° 12 pour VKR - N° 655 pour VKH

Tôle à gabarits



Longueur : 1 mètre  
Largeurs : 55, 70, 120 et 200 mm

Meules

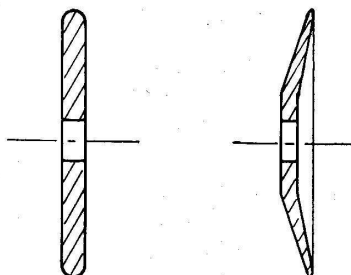

Meules demi-rondes  
Ø 175 x 30 x 8  
Ø 200 x 30 x 14

Meule assiette  
Ø 200 x 30

Boulons de fixation des outils de forme

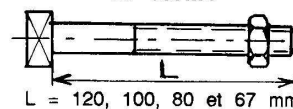

L = 120, 100, 80 et 67 mm

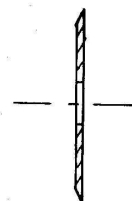

Meule caoutchouc  
pour angles aigus  
Ø 140 x 30 x 2

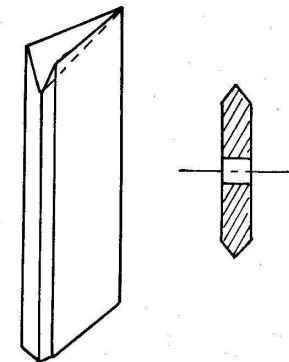

Outil pointu vertical  
et meule borazon pour dito

## OUTILLAGE de TOURNAGE MANUEL

### GOUGES à dégrossir

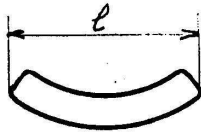

- l = 40 x 160 mm
- l = 35 x 160 mm
- l = 30 x 160 mm
- l = 30 x 240 mm
- l = 25 x 160 mm
- l = 25 x 240 mm
- l = 20 x 160 mm

### GOUGES à former demi-rondes

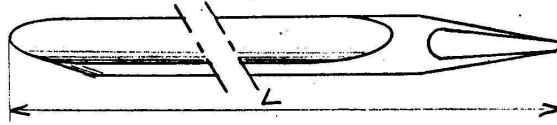
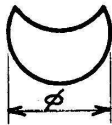

- Ø 18 x 350 mm
- Ø 16 x 350 mm
- Ø 15 x 350 mm
- Ø 14 x 350 mm
- Ø 12 x 320 mm
- Ø 10 x 320 mm

### PLANE



- l = 35 x 150 mm

### OUTILS PLATS

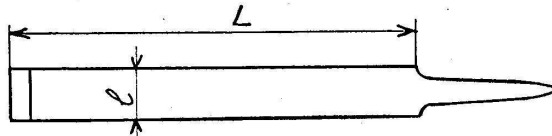

- largeur 30 x 225 mm
- largeur 25 x 225 mm
- largeur 20 x 225 mm
- largeur 16 x 165 mm

### BEDANES carrés

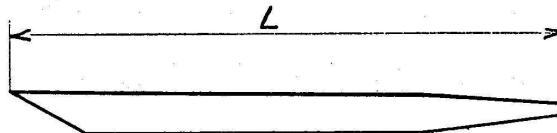

- 8 x 8 x 320 mm
- 12 x 12 x 320 mm
- 15 x 15 x 320 mm
- 7,5 x 12 x 320 mm

### BEDANES plats

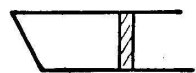

- 3 x 14 x 135 mm
- 5 x 14 x 155 mm

### GRAINS d' ORGE

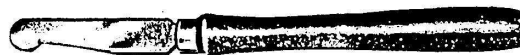

- Largeur 10 mm
- Largeur 15 mm
- Largeur 20 mm
- Largeur 25 mm
- Largeur 30 mm

### PIERRES à AFFUTER

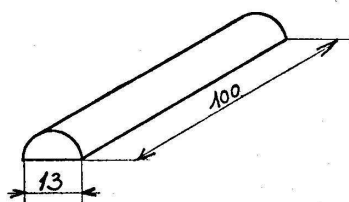

1/2 ronde

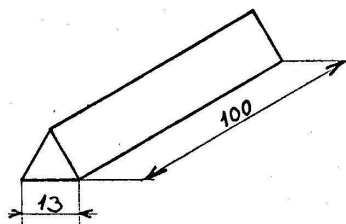

Triangulaire

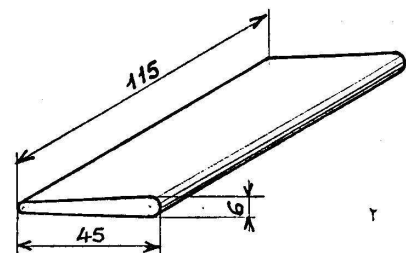

Couteau champ rond

**S****Meule pour outil de tournage pour tous types d'outils**

Grinding wheels

Schleifscheiben

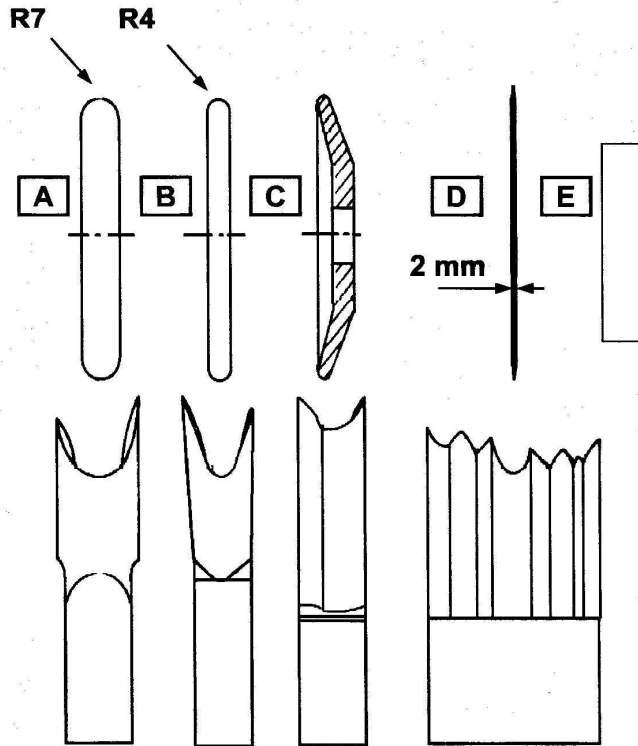
**Meule pour outil de tournage**

Ref :	Désignation	Dimensions	Acier
340R7	A Meule 1/2 Ronde R7	Ø200/14/30	
340R4	B Meule 1/2 Ronde R74	Ø175/8/30	
339	C Meule type assiette	Ø200/30	
341	D Meule Caoutchouc	Ø140/2	
3340	E Pierre à dresser les meules	Grain fin	
3341	E Pierre à dresser les meules	Grain moyen	

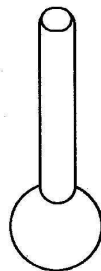
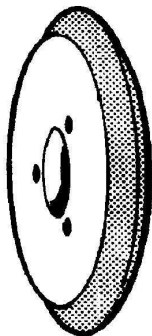
**Autres Meules meule s**

Ref :	Désignation	Dimensions	Acier
10072	Meule Borazon		
11072	Meule DIA		

 **D'autres meules sont disponibles pour tous types d'outils**

**Sanding papers and Accessoires for SANDERS  
(PD, P ,PH Hempel machine)**

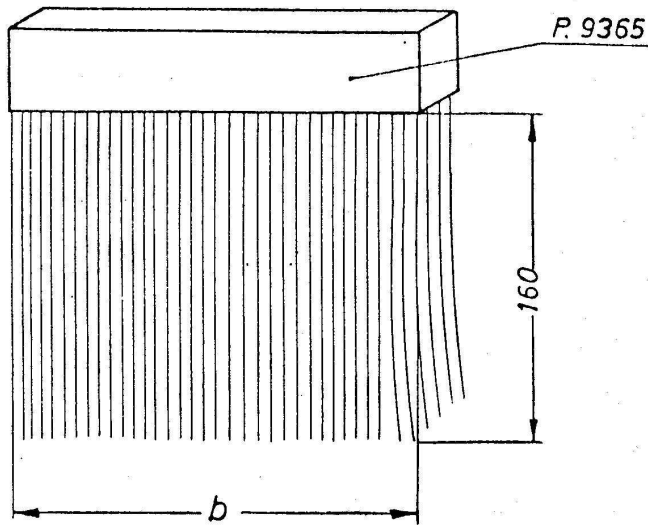

**Brush for sanders :**

- Sorgho (Yellow-Medium)
- Bahia (Brown –Soft)

**Sanding papers Roller :**

- 100 mm or 150 mm large
- 50 Meters Length
- GR 80-100-120-150-180-220

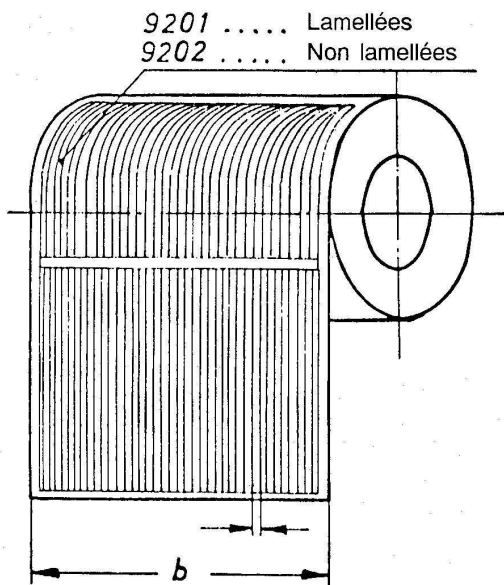

**Largeurs "b" :** 100 et 150  
**Grains :** 80, 100, 120, 150, 180

**Mandrils**

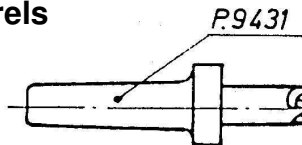

**Counter points**

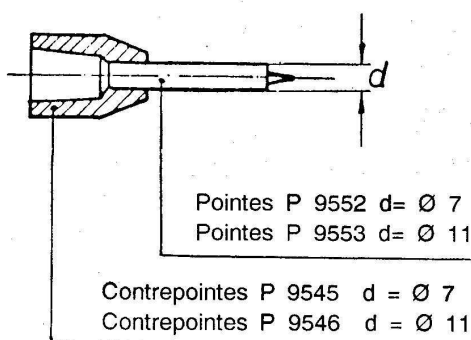

**Ejecteurs**

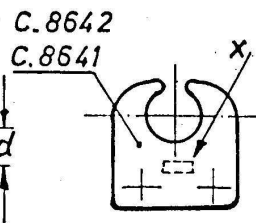

Pour toute commande, indiquer :	
le diamètre "d"	la taille "x"
Mandrins d	Ejecteurs x
Ø 10	10
Ø 12	12
Ø 14	14
Ø 16	16
Ø 18	18
Ø 20	20
Ø 22	22
Ø 24	25
Ø 31	32
Exécution spéciale pour Ø > 31	A partir de Ø 40 réf. C.8642"Gd mod"

C.8641 "Petit modèle"

Ejecteurs P 9541 D = Ø 8  
 Ejecteurs P 9551 D = Ø 12